

LMS-ES



**Horizontale Spiralgehäusepumpe nach ISO 2858 (DIN 24256)
für die Papier- und Chemische Industrie**

**Horizontal pumps according ISO 2858 (DIN 24256)
for the Pulp & Paper and Chemical Industry**

**Pompe horizontale suivant norme ISO 2858 (DIN 24256)
pour l'industrie papetière et chimique**

Leistung bis zu 2.800 m³/h
max. Förderhöhe bis zu 150 m
max. Druck bis zu 16 bar
Temperaturgrenzen von - 40° bis zu 180° C

Capacity up to 2.800 m³/h
Total head up to 150 m.w.c.
Pressure up to 16 bar max.
Working temperature from - 40° up to 180° C

Capacité jusqu'à 2.800 m³/h
Charge totale jusqu'à 150 mCE
Pression maxi jusqu'à 16 bars
Température de travail de - 40 à 180° C

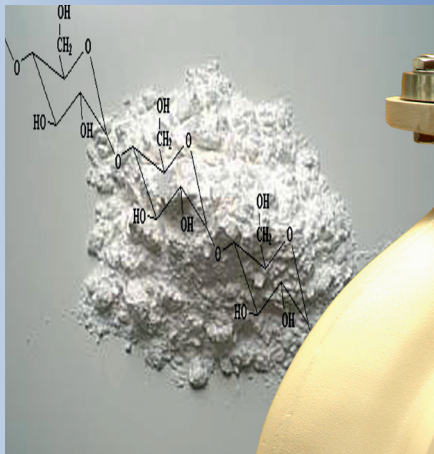

LMS-ES	Laufrad / Impeller / Roue	Design	Optionen / options / options
Hauptvorteile	Offenes Laufrad Quick-Close-System Hoher Wirkungsgrad	Schwere Lagerung Kompaktes Baukastensystem Schwere, nachstellbare Schleißwand	Patronenmonierte GLRD Öl- oder Fettschmierung Viele Werkstoffe lieferbar
Advantages	Open impeller Quick-Close-System High efficiency	Heavy bearing modular design Heavy, adjustable wear plate	Cartridge seals Oil or grease lubricated Different materials available
Avantages	Roue ouverte Quick close system Haut rendement	Palier résistant Design modulaire Plaque d'usure résistante et réglable	Cartouche de joints Lubrification par huile ou graisse Livrabale en différentes matière

Abmessungen – Outline drawing – Dimensions

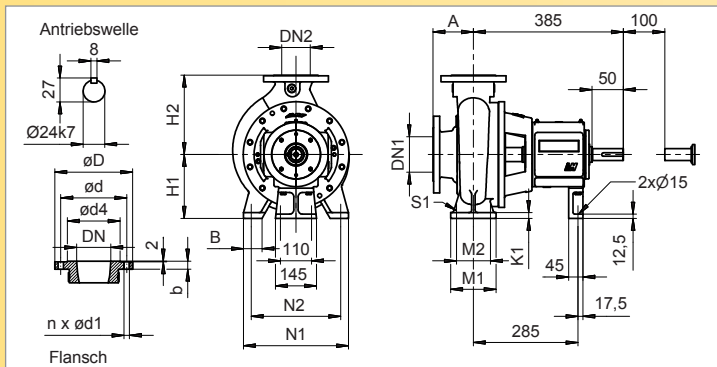

Type LMS 032-200 - LMS 050-200

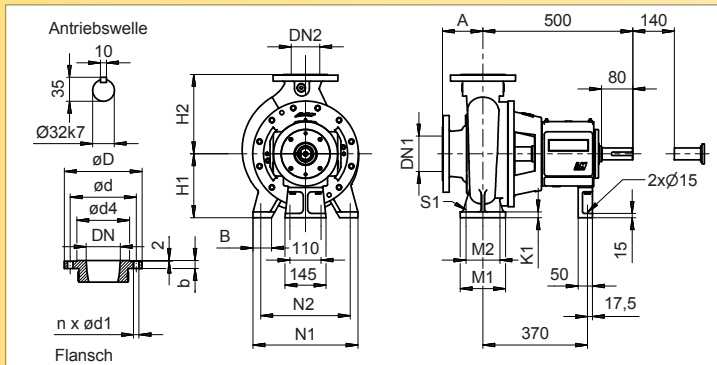

Type LMS 065-200 - LMS 50-315

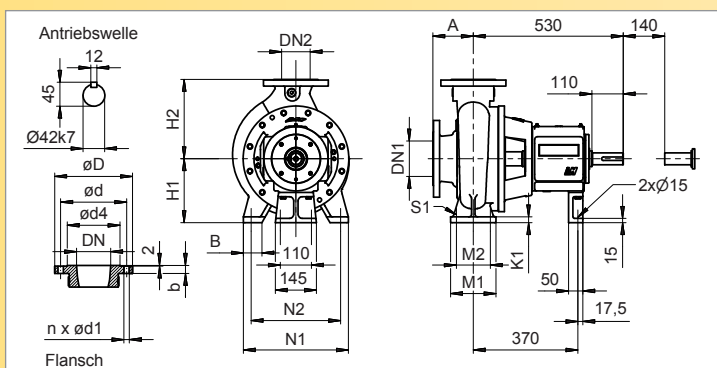

Type LMS 100-250 - LMS 125-400

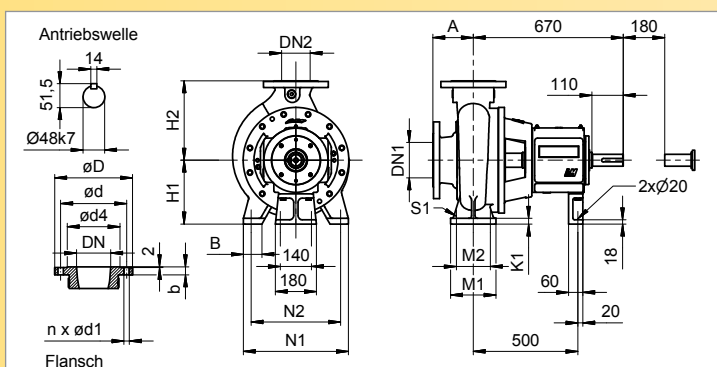

Type LMS 200-250 - LMS 200-400

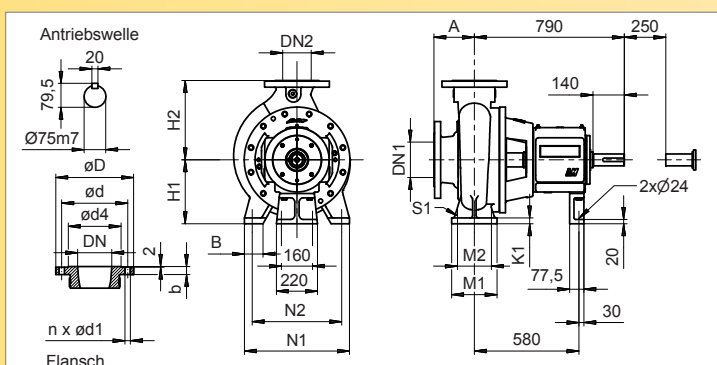

Type LMS 250-400 - LMS 300-600

Abmessungen – Outline drawing – Dimensions

Type	BG	DN 1	DN 2	A	H1	H2	B	M1	M2	N1	N2	S1	K1	ca. KG
32-200	1	050	032	080	160	180	45	100	70	230	190	15	15	65
40-200	1	065	040	080	160	180	45	100	70	255	212	15	15	66
50-200	1	080	050	080	160	180	45	100	70	255	212	15	15	66
65-200	2	100	065	100	180	225	55	125	95	300	250	15	18	100
80-200	2	125	080	125	180	250	55	125	95	330	280	15	18	100
32-250	2	050	032	100	180	225	55	125	95	300	250	15	18	103
40-250	2	065	040	100	180	225	55	125	95	300	250	15	18	103
50-250	2	080	050	125	180	225	55	125	95	300	250	15	18	105
65-250	2	100	065	125	200	250	65	160	120	340	280	19	20	107
80-250	2	125	080	125	225	280	65	160	120	370	315	19	20	112
40-315	2	065	040	125	225	280	55	125	95	330	280	15	18	131
50-315	2	080	050	125	225	280	55	125	95	330	280	15	18	141
100-250	3	125	100	140	225	280	65	160	120	370	315	19	20	162
125-250	3	150	125	140	250	355	65	160	120	370	315	19	20	178
150-250	3	200	150	160	280	375	85	200	150	470	400	24	20	208
65-315	3	100	065	125	225	280	65	160	120	370	315	19	20	167
80-315	3	125	080	125	250	315	65	160	120	370	315	19	20	172
100-315	3	125	100	140	250	315	65	160	120	370	315	19	20	182
125-315	3	150	125	140	280	355	85	200	150	470	400	24	20	102
100-400	3	125	100	140	280	355	85	200	150	470	400	24	20	223
125-400	3	150	125	140	315	400	85	200	150	470	400	24	20	238
200-250	4	250	200	200	315	450	85	200	150	520	450	24	25	305
300-250	4	300	300	225	400	560	90	250	190	570	500	28	25	405
150-315	4	200	150	160	315	400	85	200	150	520	450	24	25	255
200-315	4	250	200	180	315	450	85	200	150	520	450	24	25	295
250-315	4	300	250	225	400	560	90	250	190	570	500	28	25	375
300-315	4	350	300	250	450	630	90	250	190	570	500	28	25	475
150-400	4	200	150	160	315	450	85	200	150	520	450	24	25	285
200-400	4	250	200	180	355	500	85	200	150	520	450	24	25	330
250-400	5	300	250	200	450	560	90	250	190	570	500	28	25	440
300-400	5	350	300	250	450	670	90	250	190	570	500	28	25	575
350-500	5	400	350	280	560	800	110	315	250	680	600	28	30	745
400-500	5	400	400	280	630	850	135	400	315	940	850	35	30	855
100-500	5	200	100	180	400	500	90	250	190	570	500	28	25	355
150-500	5	250	150	180	400	500	90	250	190	570	500	28	25	385
200-500	5	250	200	180	400	560	90	250	190	570	500	28	25	505
250-500	5	300	250	200	450	630	90	250	190	570	500	28	25	570
300-500	5	350	300	250	500	670	90	250	190	570	500	28	25	625
400-600	5	500	400	355	630	850	135	400	315	940	850	35	30	1035
500-600	5	500	500	355	710	1000	135	400	315	940	850	35	30	1175
200-600	5	300	200	200	500	630	110	315	250	680	600	28	30	805
250-600	5	300	250	225	500	710	110	315	250	680	600	28	30	885
300-600	5	400	300	250	560	800	110	315	250	680	600	28	30	970

Maße Flansche – Drilling of flanges – Dimensions des brides

DN	D	d4	b	PN 10			PN 16		
				d	d1	n	d	d1	n
032	140	072	16	100	18	4	100	18	4
040	150	081	18	110	18	4	110	18	4
050	165	100	20	125	18	4	125	18	4
065	185	119	23	145	18	8	145	18	8
080	200	130	24	160	18	8	160	18	8
100	229	155	24	180	18	8	180	18	8
150	305	212	26	240	22	8	240	22	8
200	350	266	29	295	22	8	295	22	12
250	430	320	31	350	22	12	355	26	12
300	485	370	32	400	22	12	410	26	12
350	540	419	36	460	22	16	470	26	16
400	605	482	37	515	26	16	525	30	16
500	730	585	43	620	26	20	650	33	20

Abdichtungsvarianten – Sealing devices – Variante d'étanchéité

Weichpackung - P1 & Gleitringdichtung - M2
 Softpacking - P1 & mechanical seal - M2
 Garnitures - P1 molles et mécaniques - M2

Dynamische Dichtung - DS
 Dynamic shaftseal - DS
 Etanchéité dynamique - DS

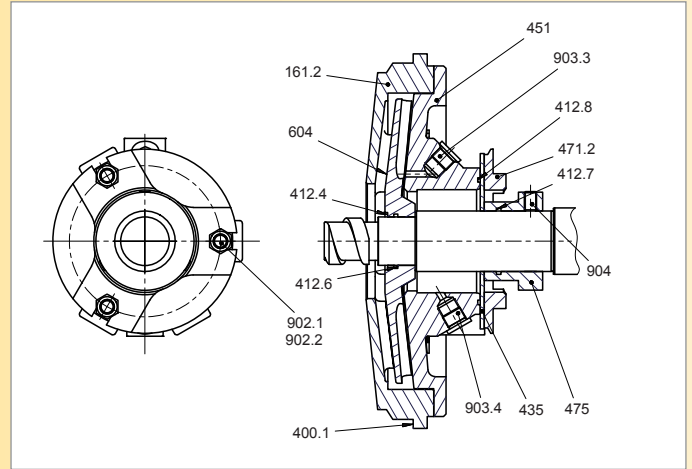
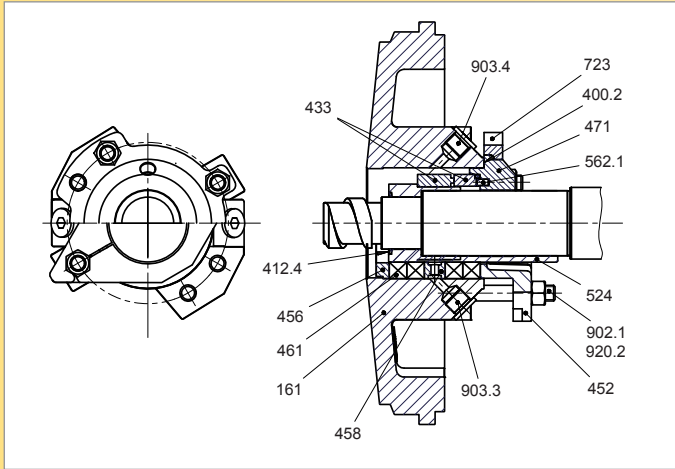

Option: CHEMOPAC SBS · CAPI/S · CMDS · LS-Lippseal

SBS - M3



CAPI/S - M4

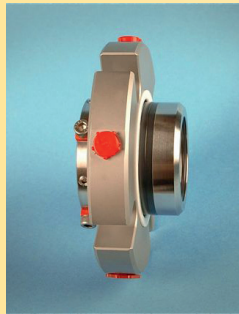

CMDS - M5

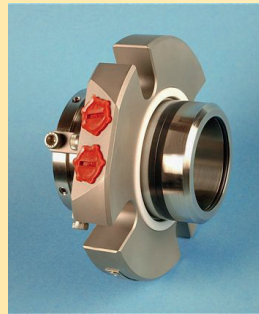

Lippseal - LS

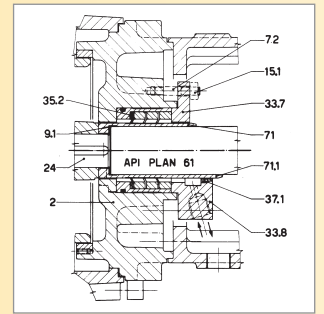

Stückliste – Spare Parts List – Liste des pièces

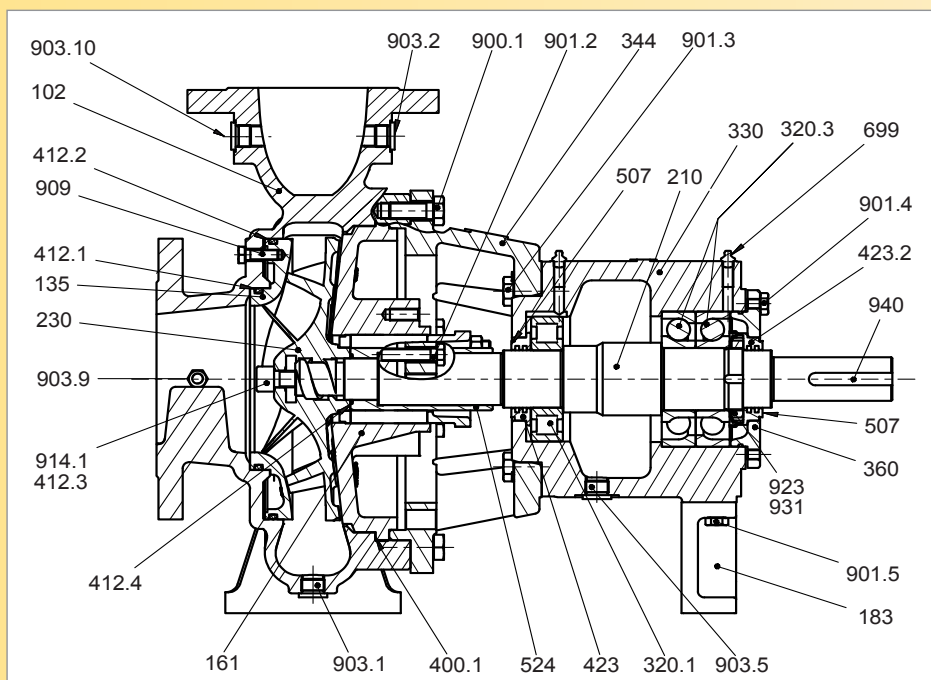

Stückliste – Spare Parts List – Liste des pièces

Position	Anzahl Quantity Nombre	Stückliste	Spare Parts List	Liste des pièces
102	1	Spiralgehäuse	Pumpcasing	volute
135	1	Schleißwand	Wear Plate	Plaque d'usure
161	1	Gehäusedeckel	Cover for mechanical	Couvercle de corps
		Packung/GLRD	seal and packing	Garniture/GLRD
161.2	1	Gehäusedeckel dyn.	Cover for dynamical Seal	Couvercle de corps
		Dichtung		étanchéité dyn.
183	1	Stützfuß	Support feed	Support arrière
210	1	Welle	Shaft	Arbre
230	1	Laufgrad	Impeller	Roue
320.1	1	Wälzlager	Bearing	Palier à roulement
320.2	2	Wälzlager	Bearing	Palier à roulement
330	1	Lagerträger	Bearing housing	Support de palier
344	1	Lagerträgerlaterne	Frame adaptor	Lanterne de palier
360	1	Lagerdeckel	Bearing cover	Couvercle de palier
400.1	1	Flachdichtung	Gasket	Joint plat
400.2	1	Flachdichtung	Gasket	Joint plat
400.3	1	Flachdichtung	Gasket	Joint plat
412.1	1	Runddichtring	O-Ring	Joint torique
412.2	1	Runddichtring	O-Ring	Joint torique
412.3	1	Runddichtring	O-Ring	Joint torique
412.4	1	Runddichtring	O-Ring	Joint torique
412.5	1	Runddichtring	O-Ring	Joint torique
412.6	1	Runddichtring	O-Ring	Joint torique
412.7	1	Runddichtring	O-Ring	Joint torique
412.8	1	Runddichtring	O-Ring	Joint torique
423	1	Labyrinthring	Labyrinth ring	Joint labyrinthe
423.2	1	Labyrinthring	Labyrinth ring	Joint labyrinthe
433	1	Gleitringdichtung	Mechn. Seal	Garniture mécanique
435	1	Statische Dichtung	Gasket	Etanchéite statique
451	1	Stopfbuchsgehäuse	Stuffing box housing	Corps presse étoupe
452	1	Stopfbuchsbrille	Packing gland	Bride presse étoupe
456	1	Grundbuchse	Bushing	Douille
458	1	Sperring	Lanternring	Joint d'arret
461	4	Stopfbuchspackung	Softpacking	garniture
471.2	1	Dichtungsdeckel	Gland	Couvercle de joint
475	1	Gegenring	Sealing ring	Joint opposé
507	2	Spritzring	Deflector	Bague de projection
524	1	Wellenschutzhülse	Shaftsleeve	Douille de protection d'arbre
562.1	1	Stift	Pin	goupille
604	1	Entlastungsrads	Expeller	Roue de décharge
636	1	Schmiernippel	Grease nipple	graisseur
685	1	Schutzende	Guard end	Protection
686	1	Schutzende	Guard end	Protection
686.3	1	Schutzende	Guard end	Protection
723	1	Flansch f. Gleitringdichtung	Flange for mechn. Seal	Bride pour garniture mécanique
840	1	Kupplung	Coupling	accouplement
890	1	Grundplatte	Baseplate	Plaque de fondation
901.1	12	Sechskantschraube	Screw	Vis six pans
901.2	2	Sechskantschraube	Screw	Vis six pans
901.3	4	Sechskantschraube	Screw	Vis six pans
901.4	4	Sechskantschraube	Screw	Vis six pans
901.5	2	Sechskantschraube	Screw	Vis six pans
901.6	3	Sechskantschraube	Screw	Vis six pans
901.7	4	Sechskantschraube	Screw	Vis six pans
901.8	2	Sechskantschraube	Screw	Vis six pans
901.9	4	Sechskantschraube	Screw	Vis six pans
901.10	4	Sechskantschraube	Screw	Vis six pans
902.1	3	Sechskantschraube	Screw	Vis six pans
903.1	1	Verschlußschraube	Plug	Bouchon fileté
903.2	1	Verschlußschraube	Plug	Bouchon fileté
903.3	1	Verschlußschraube	Plug	Bouchon fileté
903.4	1	Verschlußschraube	Plug	Bouchon fileté
903.5	1	Verschlußschraube	Plug	Bouchon fileté
904	3	Gewindestift	Stud	goupille
909	3	Sechskantschraube	Screw	Vis six pans
914.1	1	Innensechskantschraube	Screw	Vis six pans creux
920.2	3	Mutter	Nut	Ecrou
920.3	3	Mutter	Nut	Ecrou
923	1	Lagermutter	Nut for bearing	Ecrou de palier
931	1	Sicherungsblech	Washer	Tole de sécurité
940	1	Paßfeder	Key	Ressort
918	3	Fundamentschrauben	Screw for baseplate	Vis de fondations
920.4	6	Mutter	Nut	Ecrou

Kompatibilität – Interchangeability – Compatibilité

Type Position	BG/330	102	135	161	183	210	230	344	433	451	524	604
32-200	1	1	1	11	1	1	1	11	1	11	1	1
40-200	1	2	2	11	1	1	2	11	1	11	1	1
50-200	1	3	3	11	1	1	3	11	1	11	1	1
65-200	2	4	4	21	2	2	4	21	2	21	2	2
80-200	2	5	5	21	2	2	5	21	2	21	2	2
32-250	2	6	6	22	2	2	6	22	2	22	2	2
40-250	2	7	7	22	2	2	7	22	2	22	2	2
50-250	2	8	8	22	2	2	8	22	2	22	2	2
65-250	2	9	9	22	3	2	9	22	2	22	2	2
80-250	2	10	10	22	4	2	10	22	2	22	2	2
40-315	2	11	11	23	4	2	11	23	2	23	2	2
50-315	2	12	12	23	4	2	12	23	2	23	2	2
100-250	3	13	13	31	3	3	13	31	3	31	3	3
125-250	3	14	14	31	4	3	14	31	3	31	3	3
150-250	3	15	15	31	5	3	15	31	3	31	3	3
65-315	3	16	16	32	3	3	16	32	3	32	3	3
80-315	3	17	17	32	4	3	17	32	3	32	3	3
100-315	3	18	18	32	4	3	18	32	3	32	3	3
125-315	3	19	19	32	5	3	19	32	3	32	3	3
100-400	3	20	20	33	5	3	20	33	3	33	3	3
125-400	3	21	21	33	6	3	21	33	3	33	3	3
200-250	4	22	22	41	7	4	22	41	4	41	4	4
300-250	4	23	23	41	9	4	23	41	4	41	4	4
150-315	4	24	24	42	7	4	24	42	4	42	4	4
200-315	4	25	25	42	7	4	25	42	4	42	4	4
250-315	4	26	26	43	9	4	26	43	4	43	4	4
300-315	4	27	27	43	10	4	27	43	4	43	4	4
150-400	4	28	28	44	7	4	28	44	4	44	4	4
200-400	4	29	29	44	8	4	29	44	4	44	4	4
250-400	5	30	30	51	12	5	30	51	5	51	5	5
300-400	5	31	31	51	12	5	31	51	5	51	5	5
350-500	5	32	32	52	14	5	32	52	5	52	5	5
400-500	5	33	33	52	15	5	33	52	5	52	5	5
100-500	5	34	34	53	11	5	34	53	5	53	5	5
150-500	5	35	35	53	11	5	35	53	5	53	5	5
200-500	5	36	36	53	11	5	36	53	5	53	5	5
250-500	5	37	37	53	12	5	37	53	5	53	5	5
300-500	5	38	38	53	13	5	38	53	5	53	5	5
400-600	5	39	39	54	15	5	39	54	5	54	5	5
500-600	5	40	40	54	16	5	40	54	5	54	5	5
100-600	5	41	41	55	12	5	41	55	5	55	5	5
200-600	5	42	42	55	13	5	42	55	5	55	5	5
250-600	5	43	43	55	15	5	43	55	5	55	5	5
300-600	5	44	44	55	14	5	44	55	5	55	5	5

Empfohlene Ersatzteile – recommended spare parts – Pièces recommandées

Pumpenanzahl Used pumps Numéro de pompe	Service Set's service	102	135	161	183	210	230	344	433	451	524	604
1	1		1			1	1		1			1
3	3		2			2	2		2	1	1	2
8	8	1	3	1		3	3	1	4	1	1	3

Konstruktionsmerkmale – Construction data – Données de construction

Bauteil Part Pièce	Gehäuse / 102 Pump casing / 102 Corps de pompe / 102	Stopfbuchsdeckel / 161 Cover / 161 Couvercle / 161	Schleißwand / 135 Wear plate / 135 Plaque d'usure / 135	Laufgrad / 210 Impeller / 210 roue / 210	Welle & Hülse / 210 Shaft & Sleeve / 210 Arbre et douille / 210
Ausführung-A Construction-A Construction-A	GG 25	GG 25	GG 25	GG 25	1.4460
Ausführung-B Construction-B Construction-B	BZN9	BZN9	BZN9	BZN9	1.4460
Ausführung-C Construction-C Construction-C	Hastelloy C	Hastelloy C	Hastelloy C	Hastelloy C	Hastelloy C
Ausführung-S Construction-S Construction-S	1.4462	1.4462	1.4462	1.4462	1.4460

Nebendichtungen – Joints & Gaskets – Joints

Flachdichtung Gasket Joint plat	C-4430 PTFE/Glas	- 35° C + 380° C - 150° C + 250° C	PH 3-12 PH 0-14
O-Ring O-Ring Joint torique	NBR EPDM PTFE	- 35° C + 100° C - 45° C + 140° C - 150° C + 250° C	pH = Mediumabhängig pH = Dependent on Medium pH = dépend du milieu

Lagertypen – Ball-bearing type – Type de palier

Lagerstuhlgröße Support Size Taille de palier	LAGER PUMPENSEITIG PUMP SIDE BEARING Palier coté pompe n=1450 / 2950 A	LAGER KUPPLUNGSSEITIG COUPLING SIDE BEARING Palier coté accouplement n=1450 / 2950 B	Ölmenge / Lagerträger Quantity of Oil / Support Quantité d'huile/support n=1450 / 2950	Nachschmierung / Fett Lubricate with Grease Graissage n=1450 / 2950	
				A	B
BG 1	NUP 307 ECJ	BECBM 7308	~ 0,2 ltr	12 g	20 g
BG 2	309 ECJ	7310	~ 0,5 ltr	18 g	30 g
BG 3	311 ECJ	7312	~ 0,6 ltr	25 g	35 g
BG 4	313 ECJ	7314	~ 0,9 ltr	30 g	45 g
BG 5	317 ECJ	7318	~ 2,2 ltr	45 g	65 g

Stopfbuchsenringe – Softpacking – Bague presse étoupe

Lagerstuhlgröße Support Size Taille de palier	d x D x Ø (mm)
BG 1	40 x 60 x 10
BG 2	50 x 70 x 10
BG 3	60 x 85 x 12,5
BG 4	70 x 95 x 12,5
BG 5	90 x 122 x 16

T.-max. Medium – T.-max. Medium – Temp. max

Fett: max. 120° C / Öl: max. 180° C	Grease: max. 120° C / Oil: max. 180° C	Graisse: max. 120° C / Huile: max. 180° C
-------------------------------------	--	---

Sammel-Kurven – Selection chart – courbe de fonctionnement

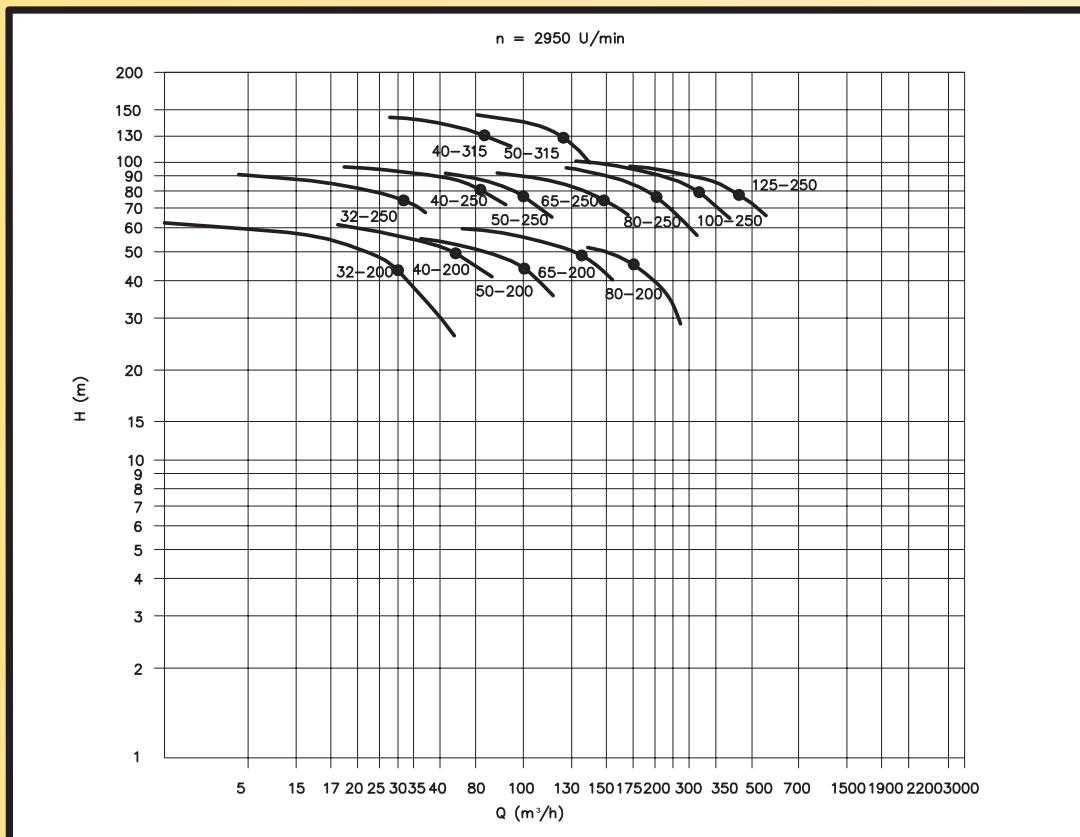
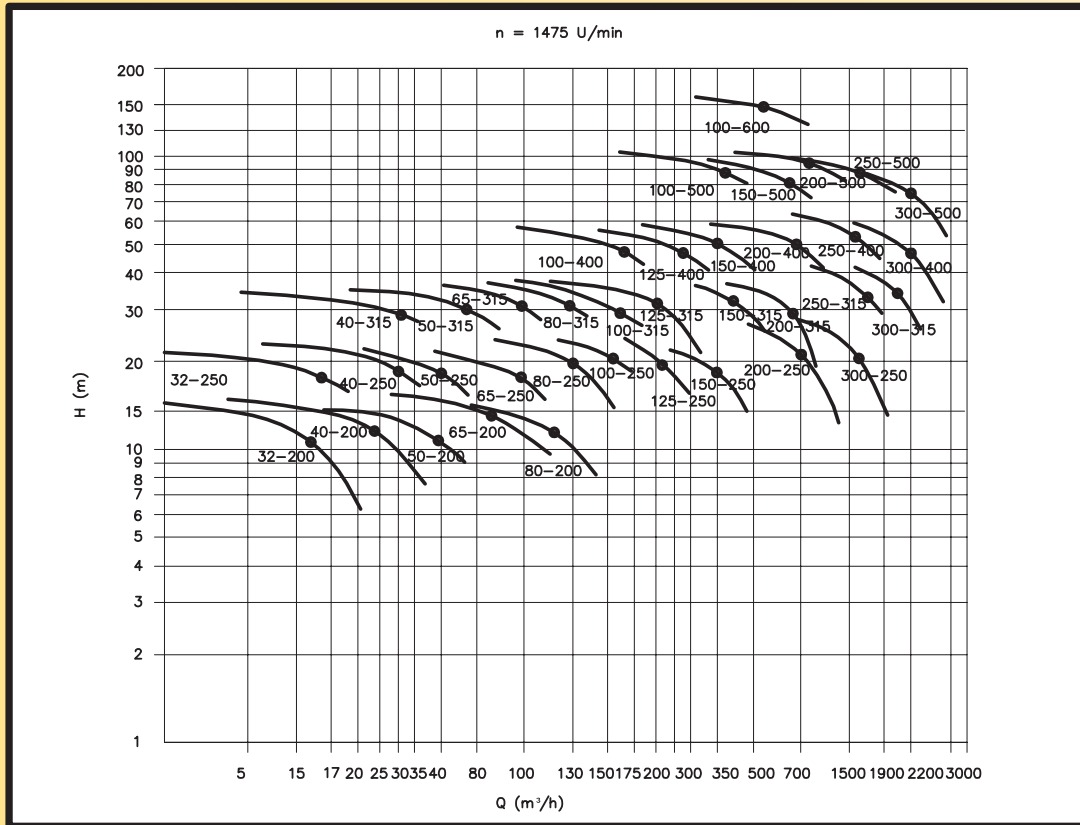

HINWEIS

L&M behält sich ausdrücklich das Recht auf technische Änderungen vor.
Dies gilt sowohl für sämtliche Maß- als auch Leistungsangaben!
Irrtum vorbehalten!

NOTE

L&M shall be free to make, in any moment and without advance
written notice, technical and constructional modifications to
improve their efficiency, reliability and life!
Errors excepted!

NOTE

L&M se garde le droit de toutes modifications techniques
ainsi que des cotes et des caractéristiques!
Erreurs exceptées!